

TACTIC

3D view

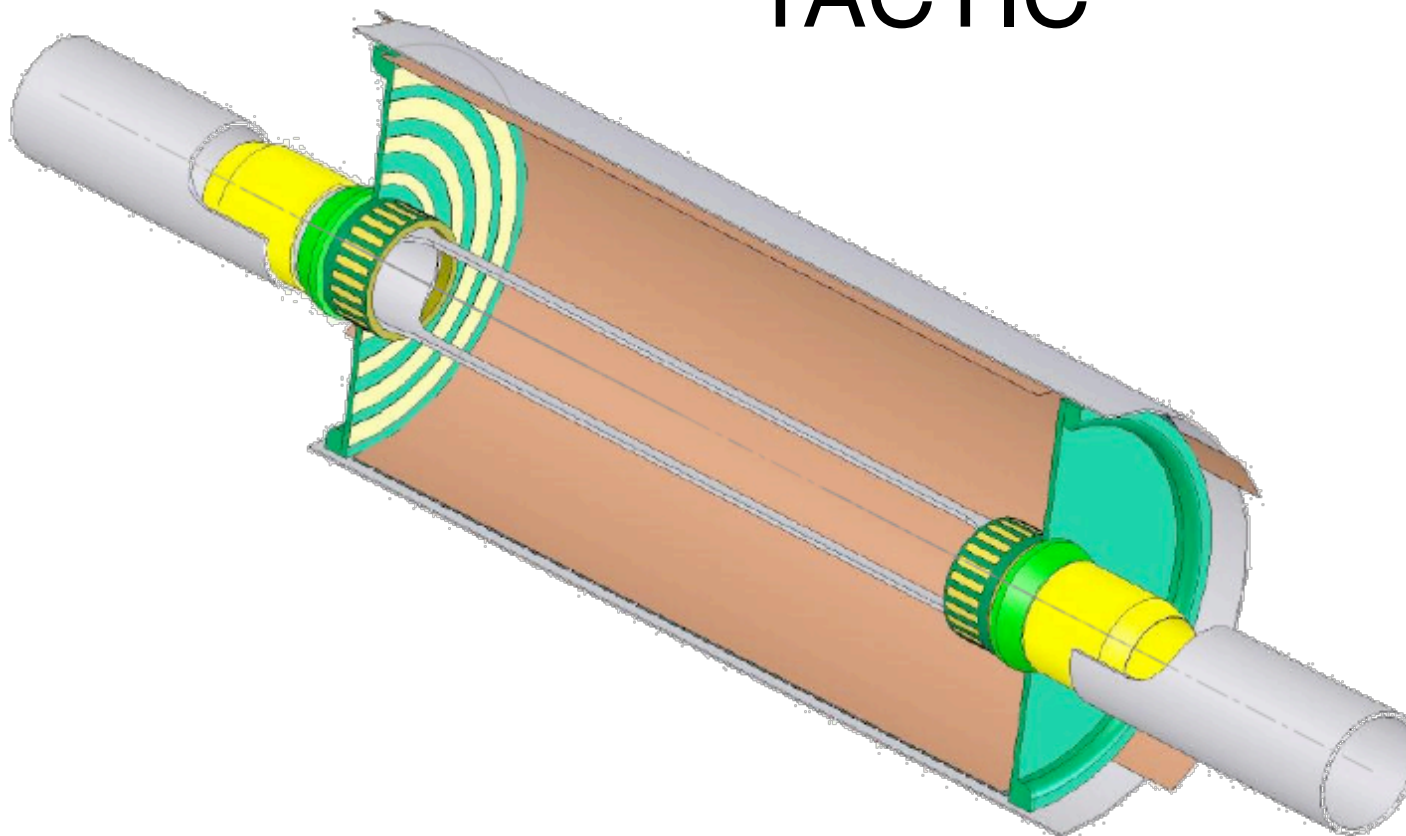

Schematic view

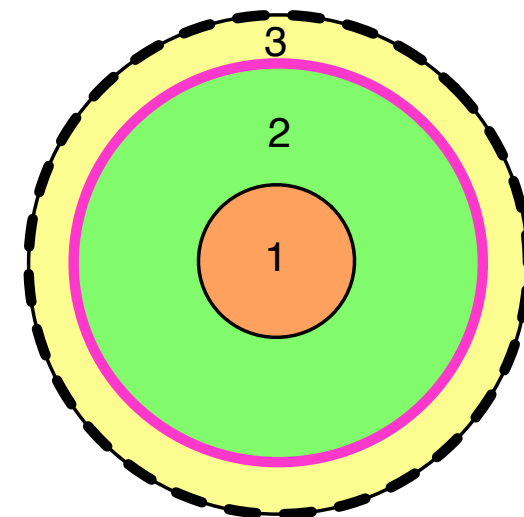
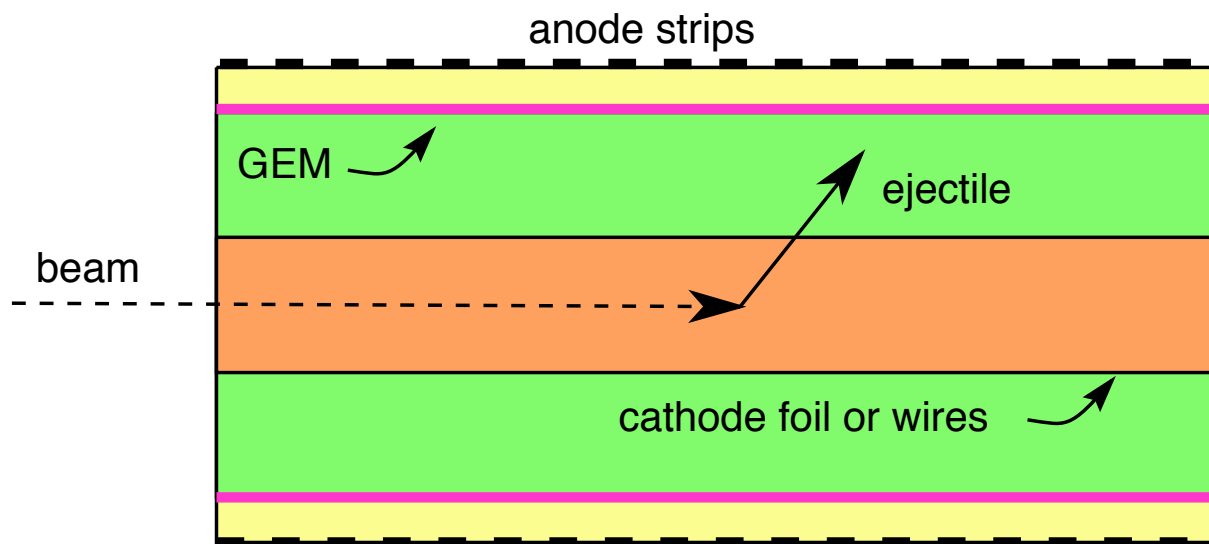

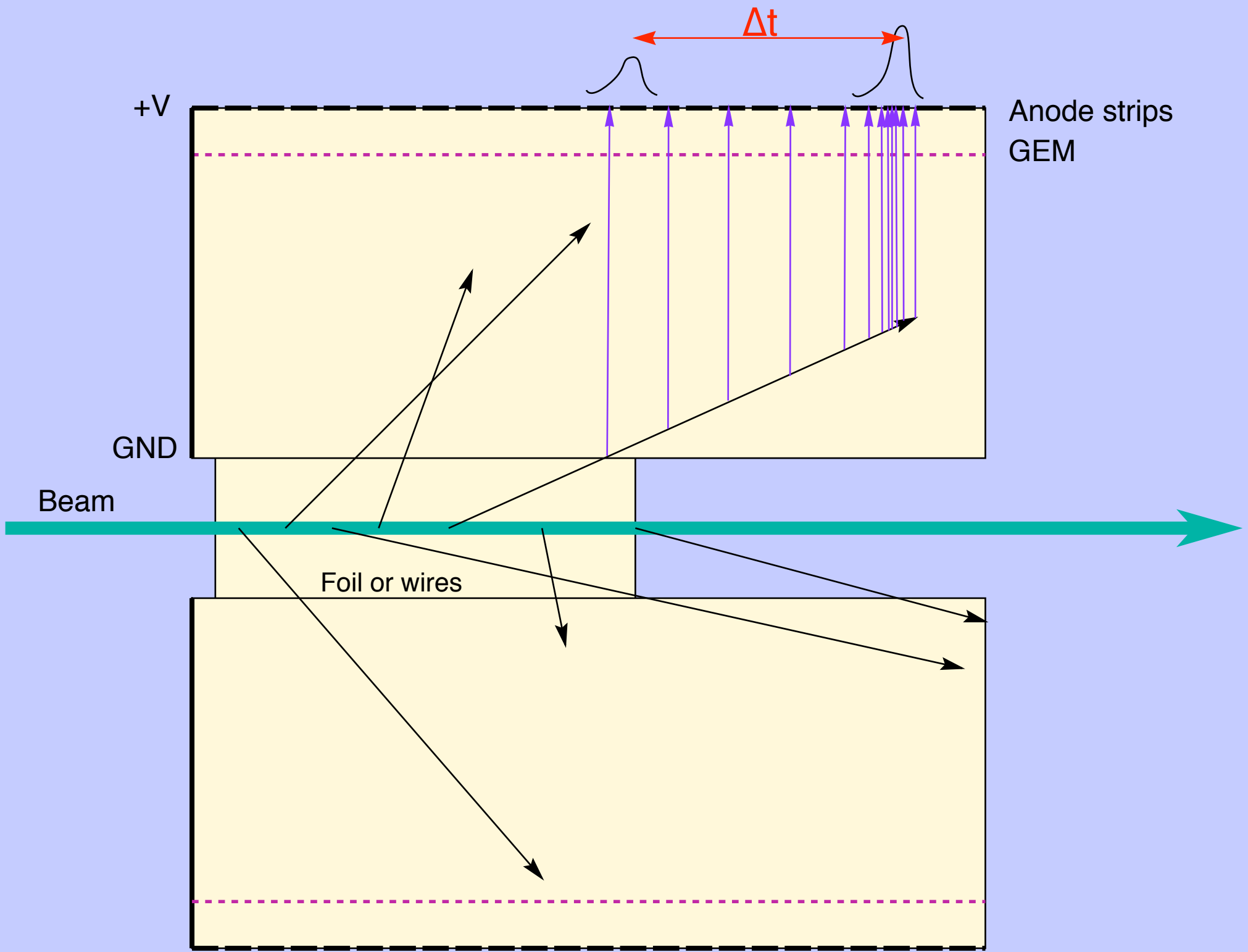

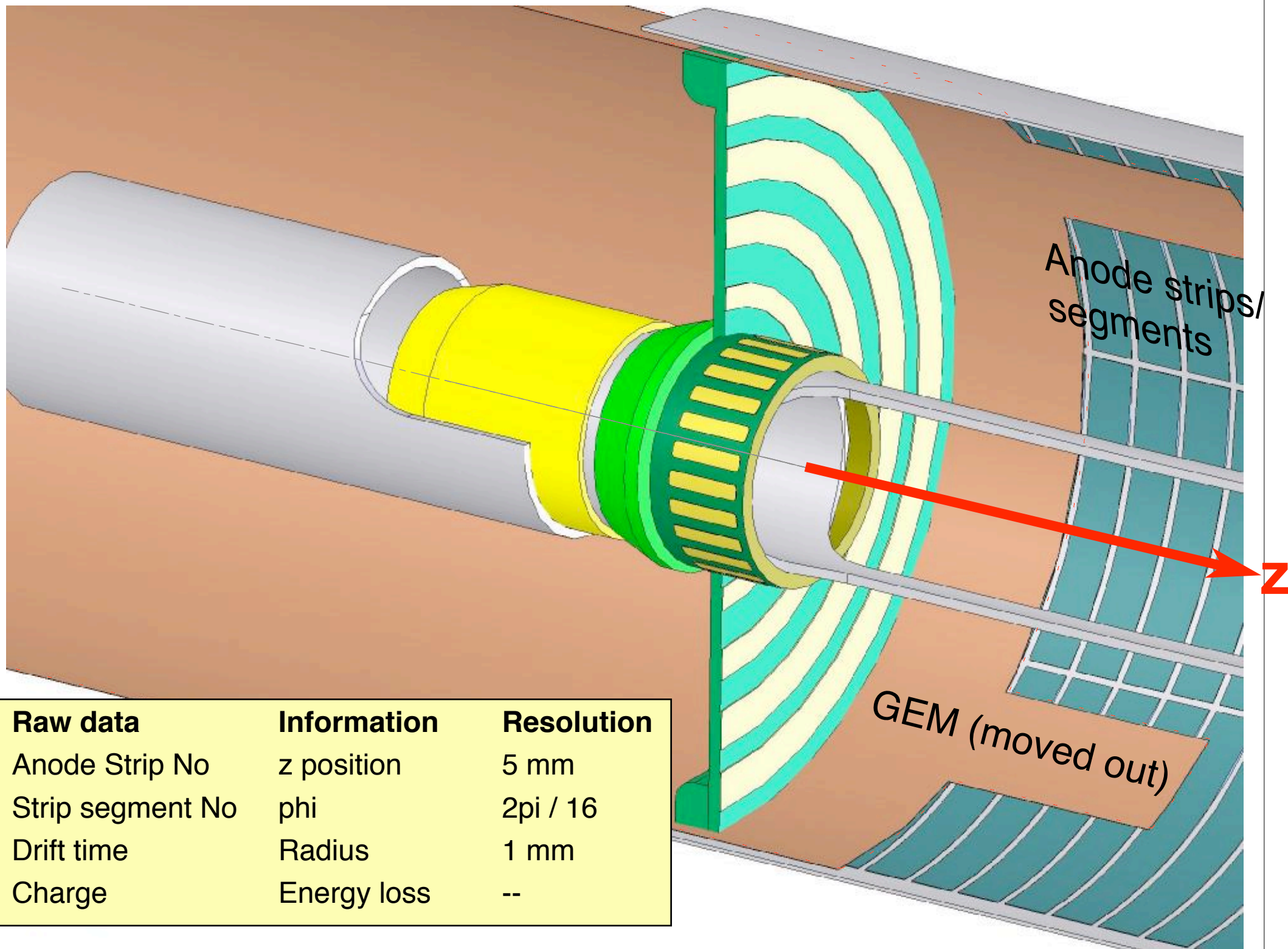

Raw data	Information	Resolution
Anode Strip No	z position	5 mm
Strip segment No	phi	$2\pi / 16$
Drift time	Radius	1 mm
Charge	Energy loss	--

The Gas Electron Multiplier (GEM)

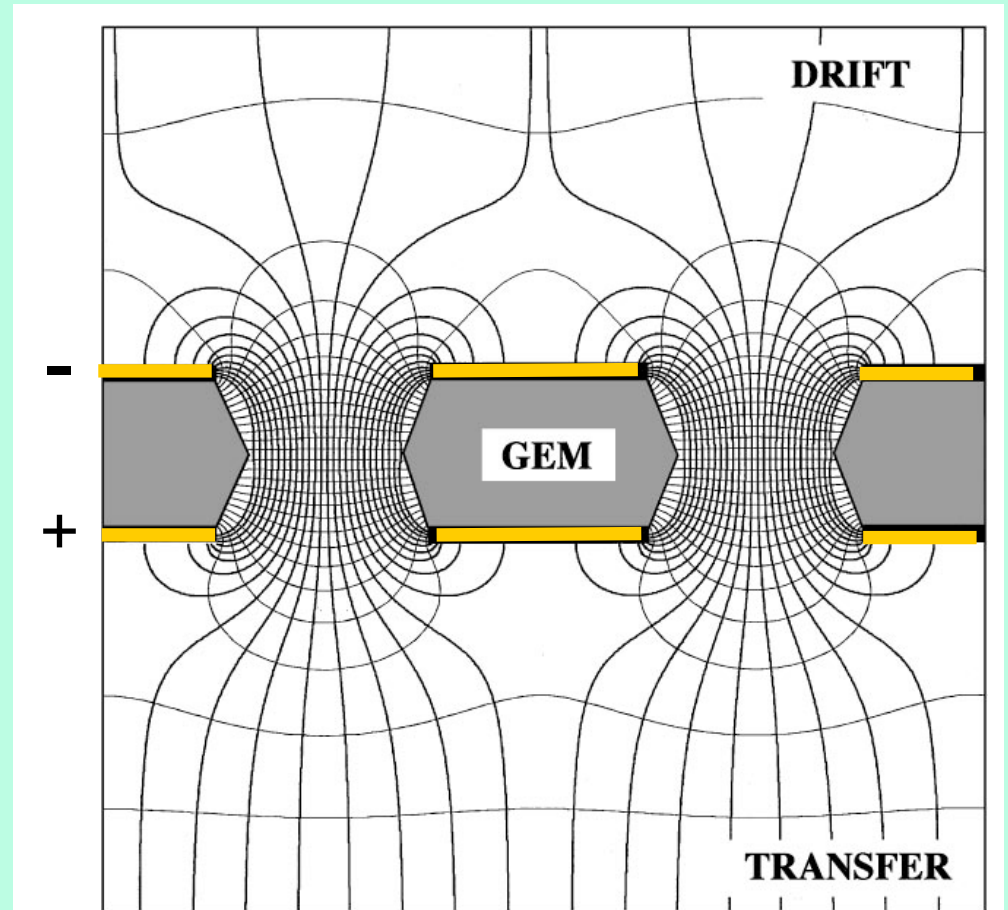
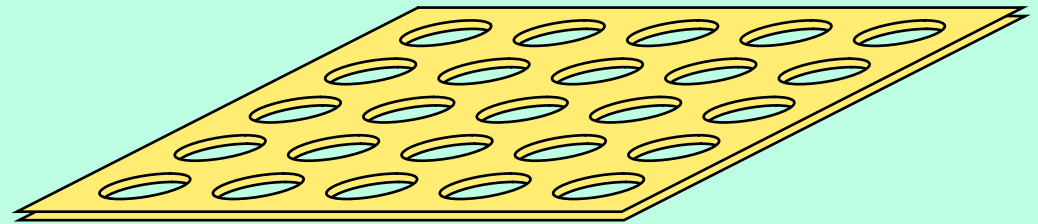
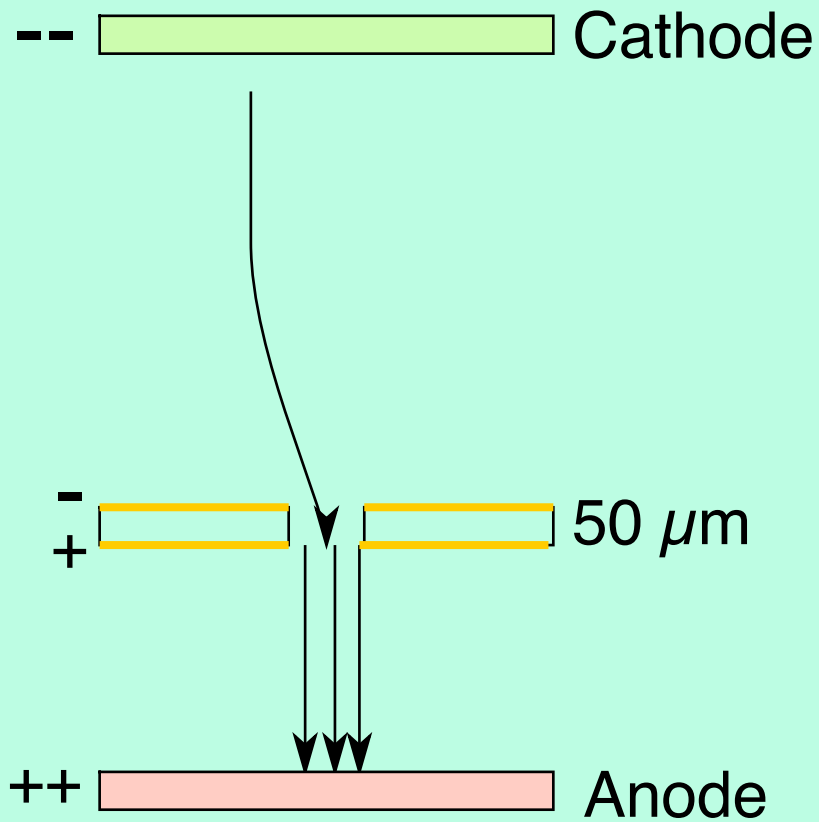

150 μm

- Introduced 1996 by F. Sauli
- 100% transmission
- High gain (up to 10^4)
- Double sided printed circuit technology
- Preserving the ionization pattern to a large extend

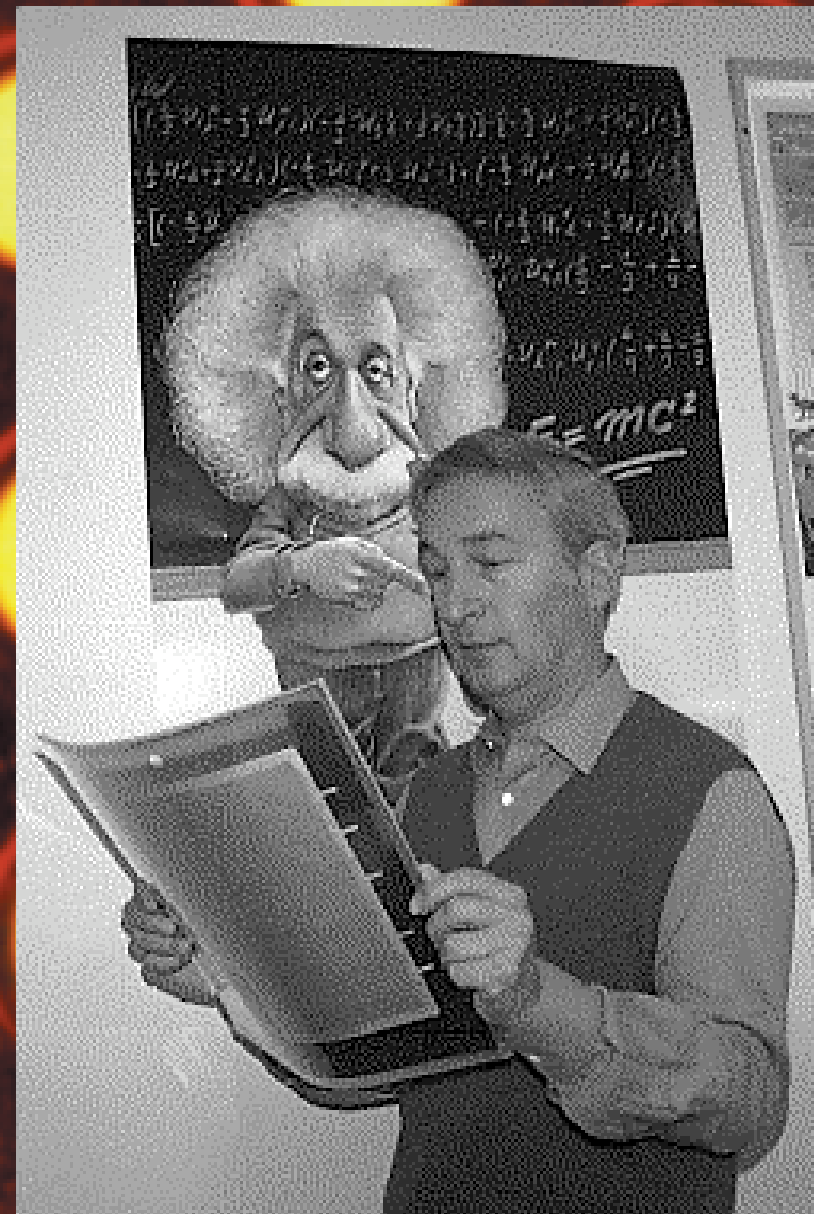

GEM Gain in Different Ar-CO₂ Mixtures

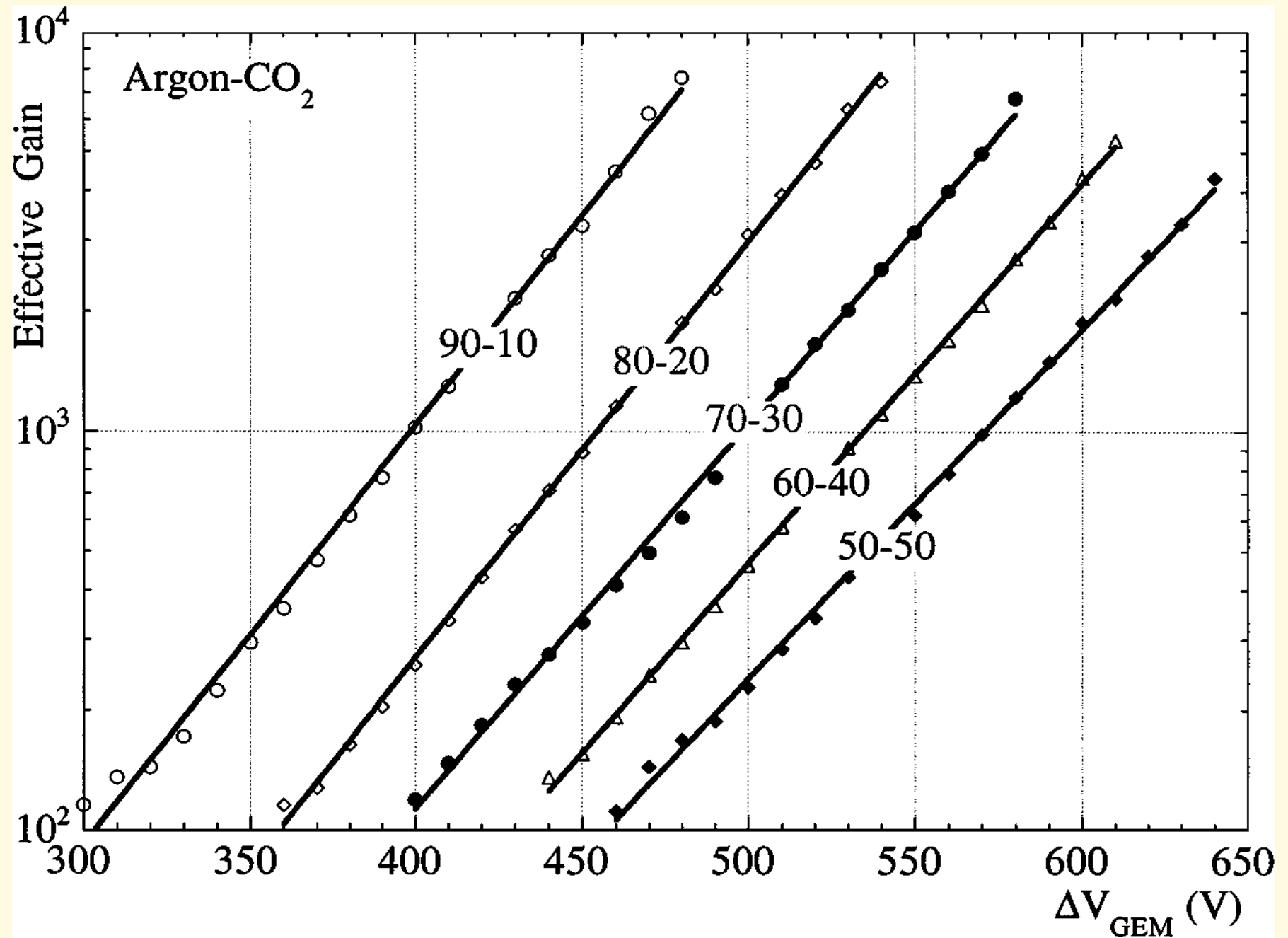

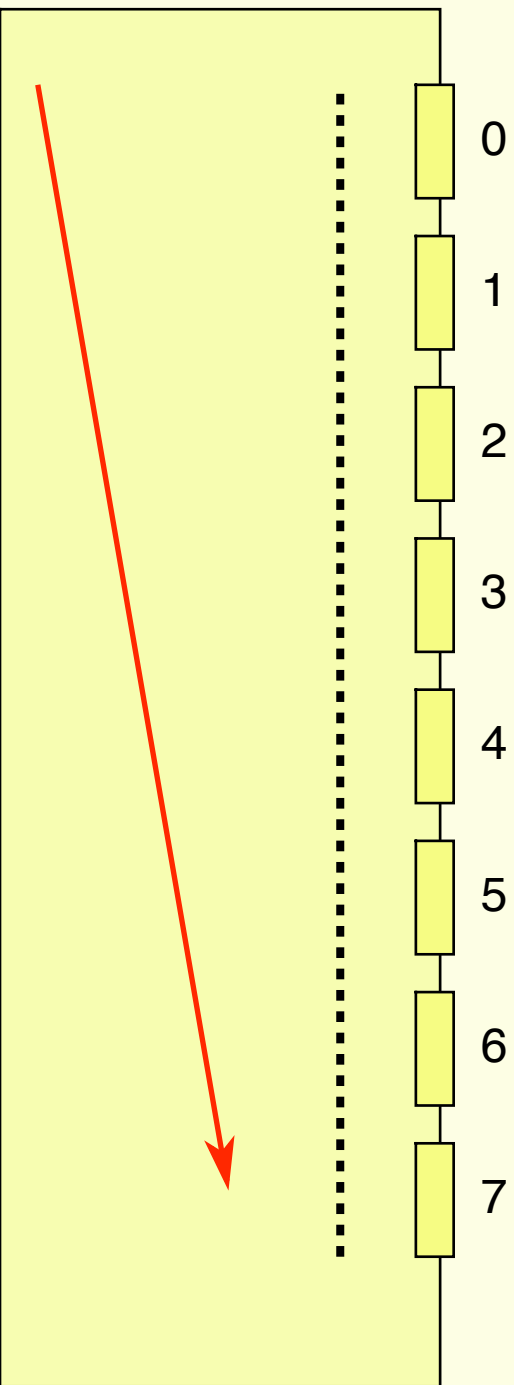

Signal

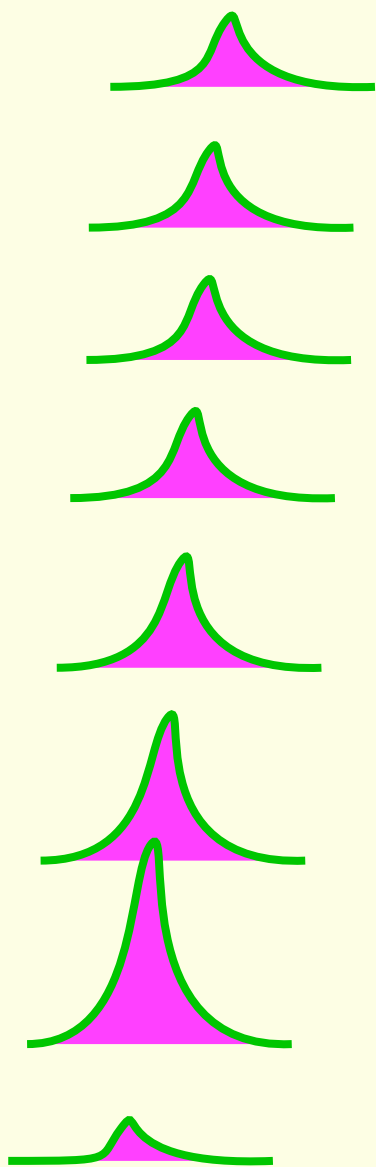

Timing

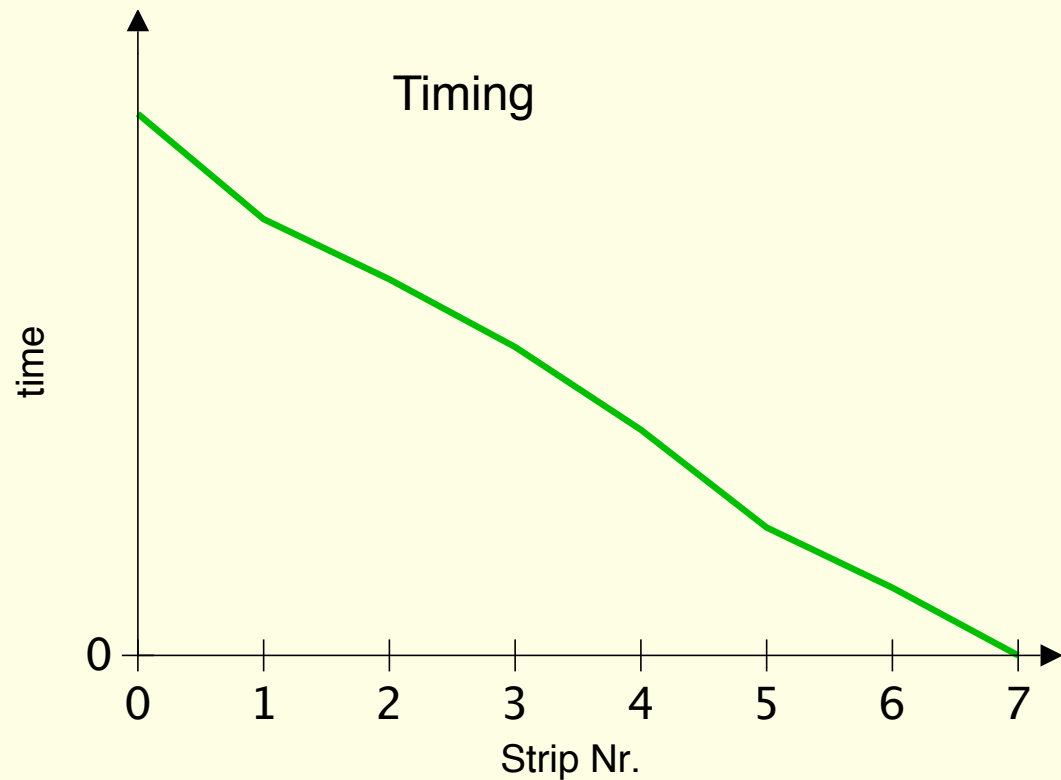

Stopping

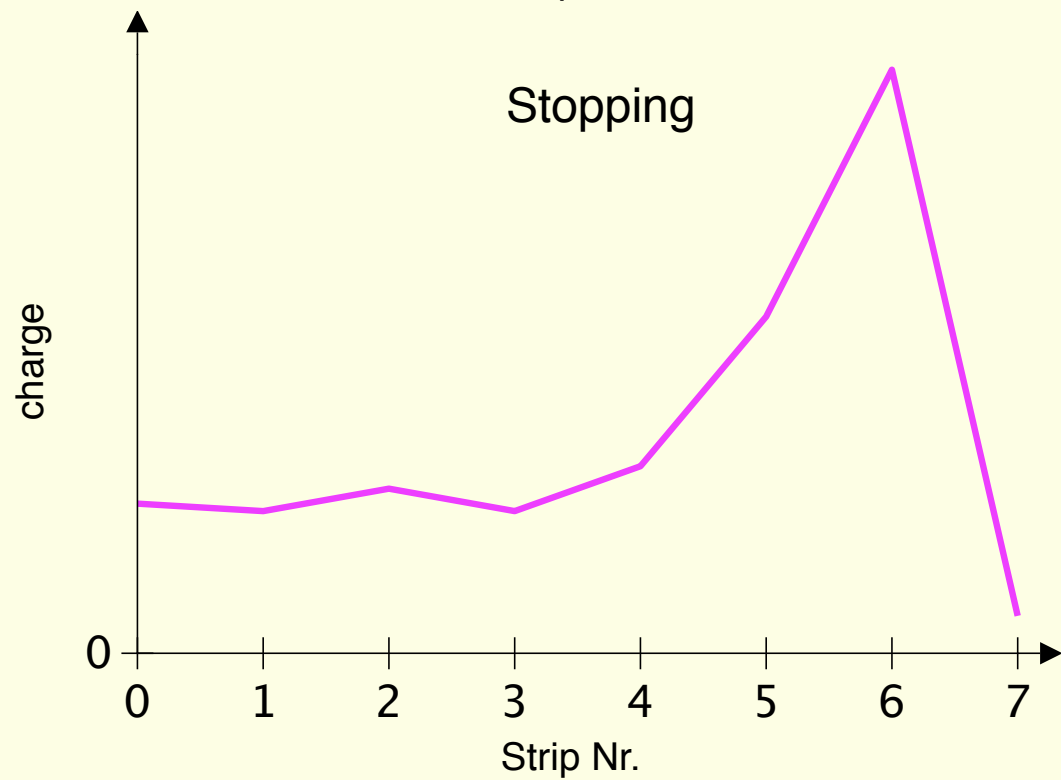

DAQ electronics

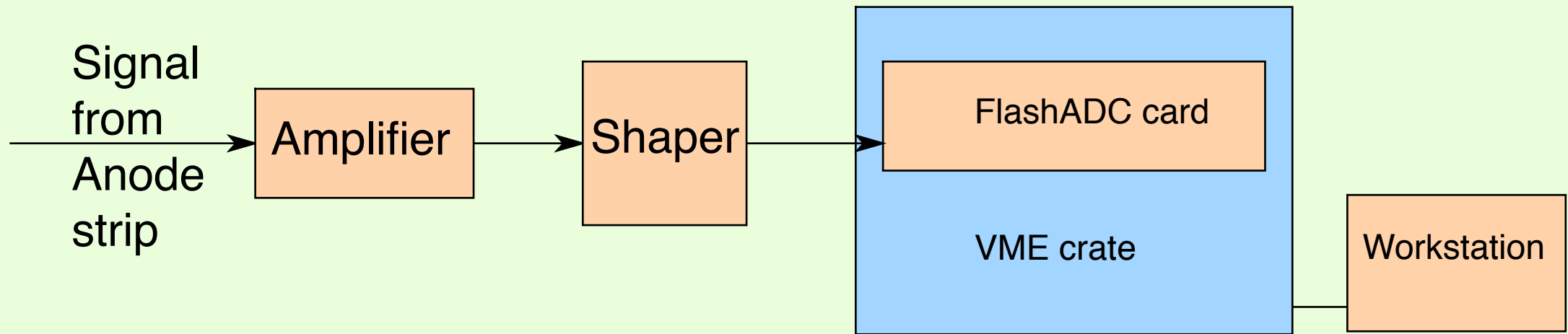

Flash ADC

Sampling rate 50-70 Ms/s

FPGA algorithm to extract time and charge

Needs good S/N ratio (at least 10)

Raise time should be large enough

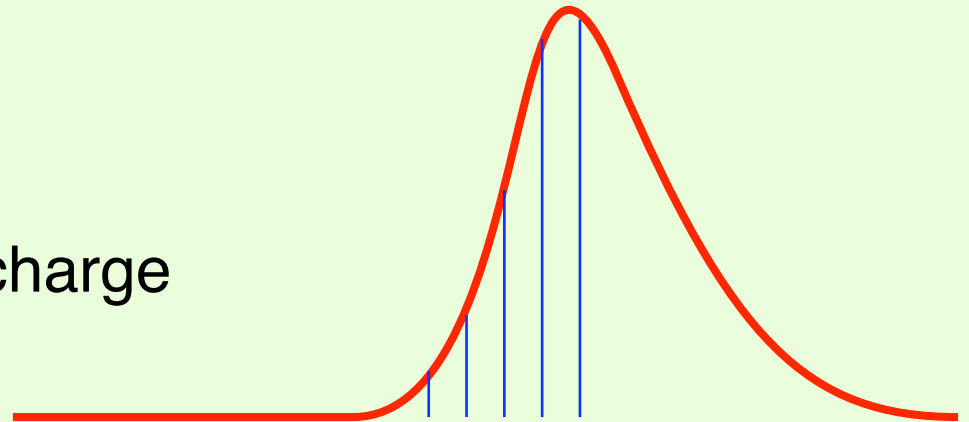

Testchamber

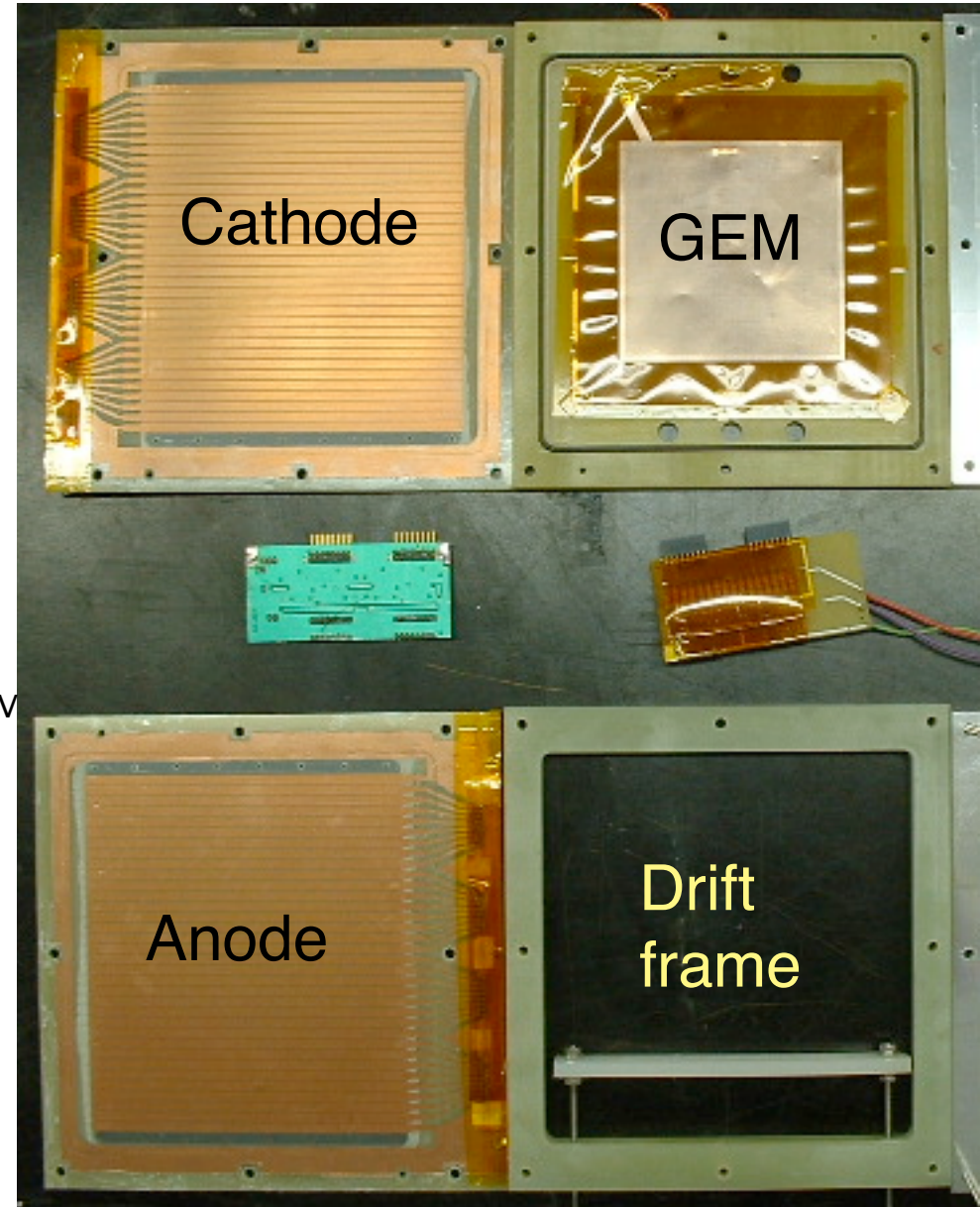
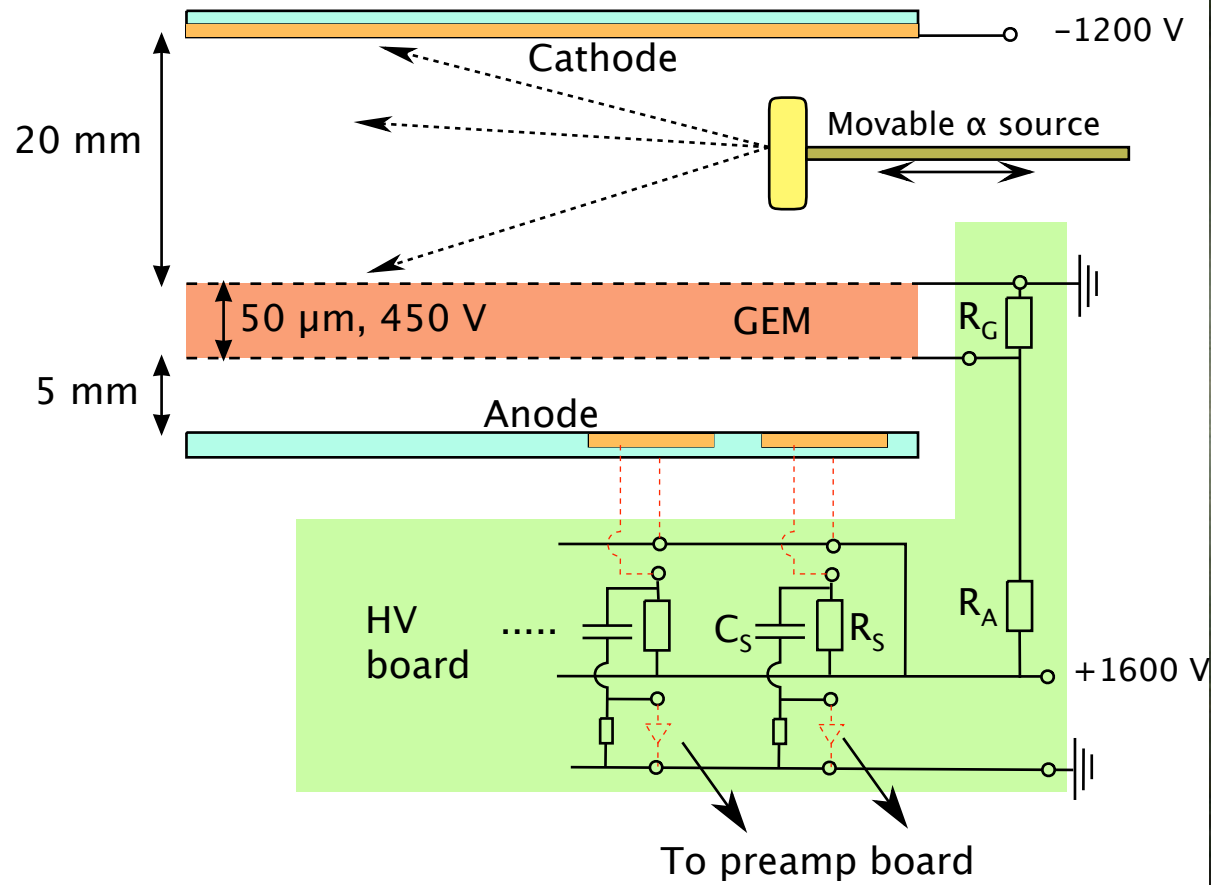

Pulse form

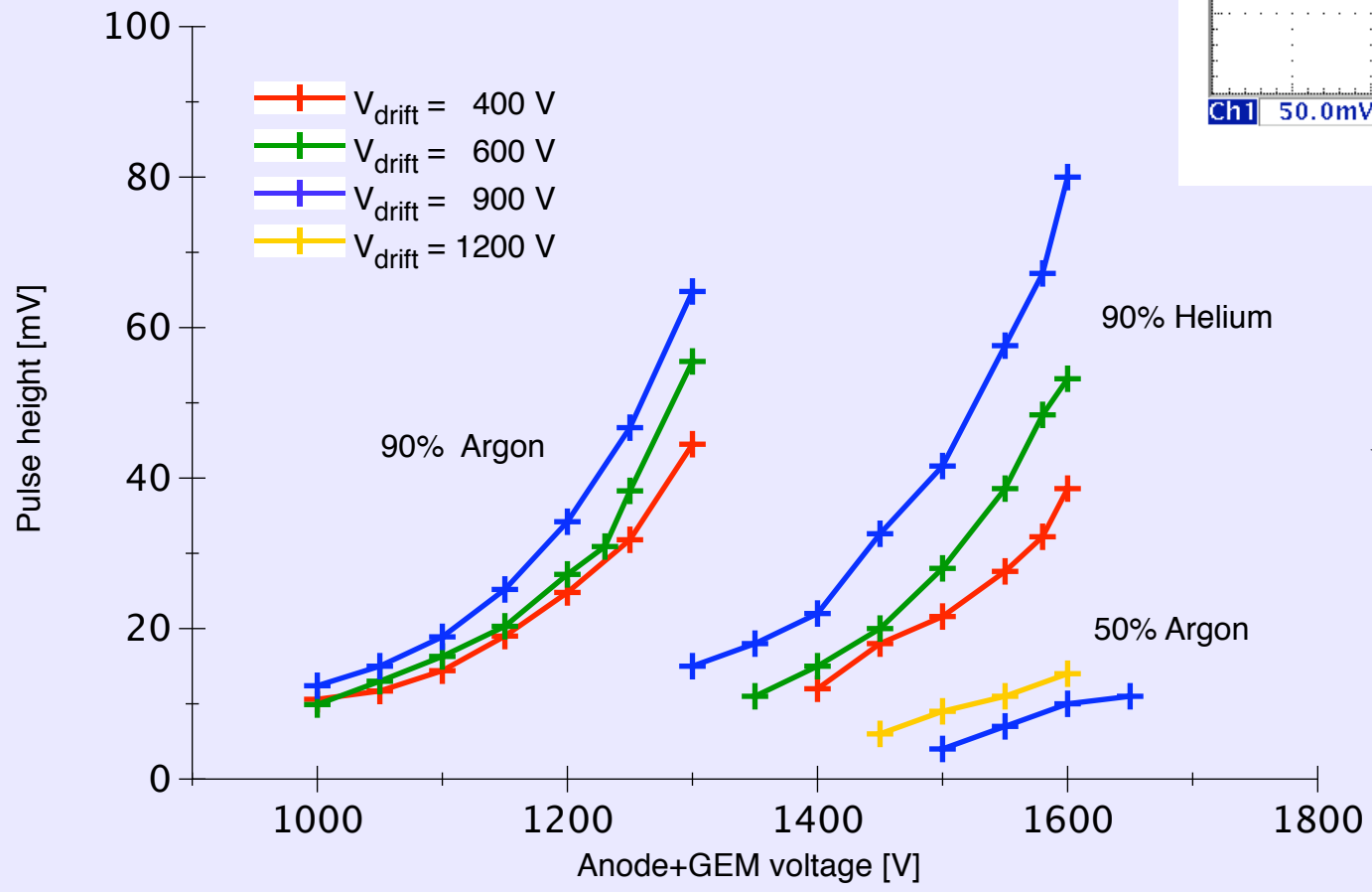
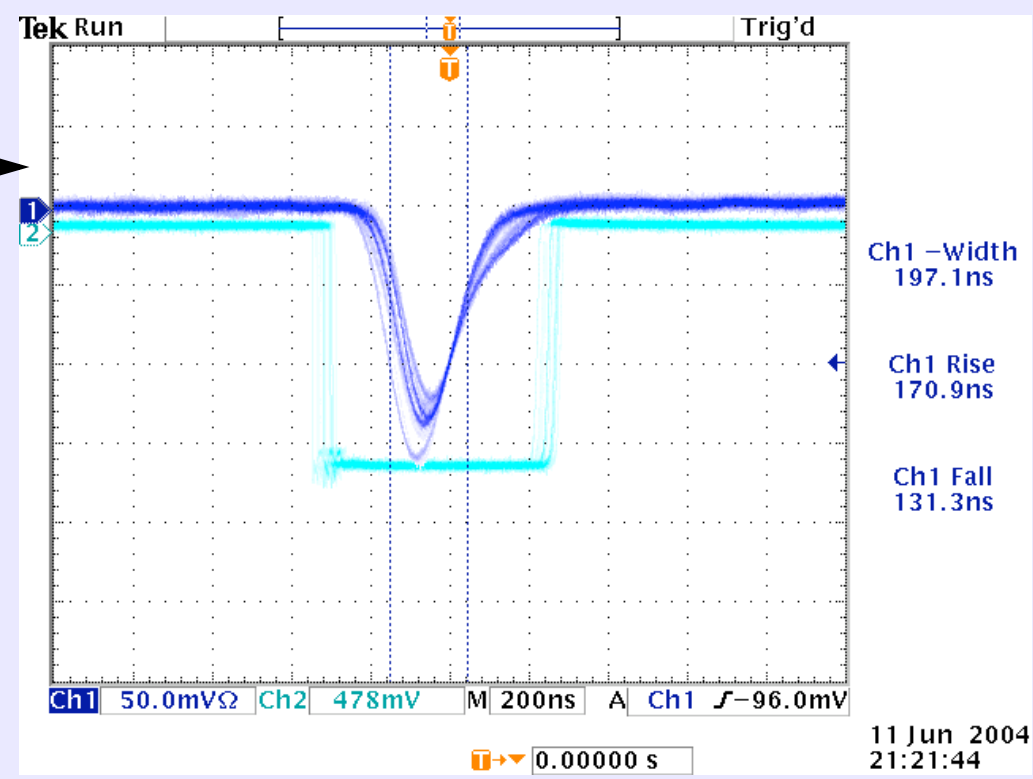

Pulse height
vs.
GEM voltage

Test chamber track reconstruction

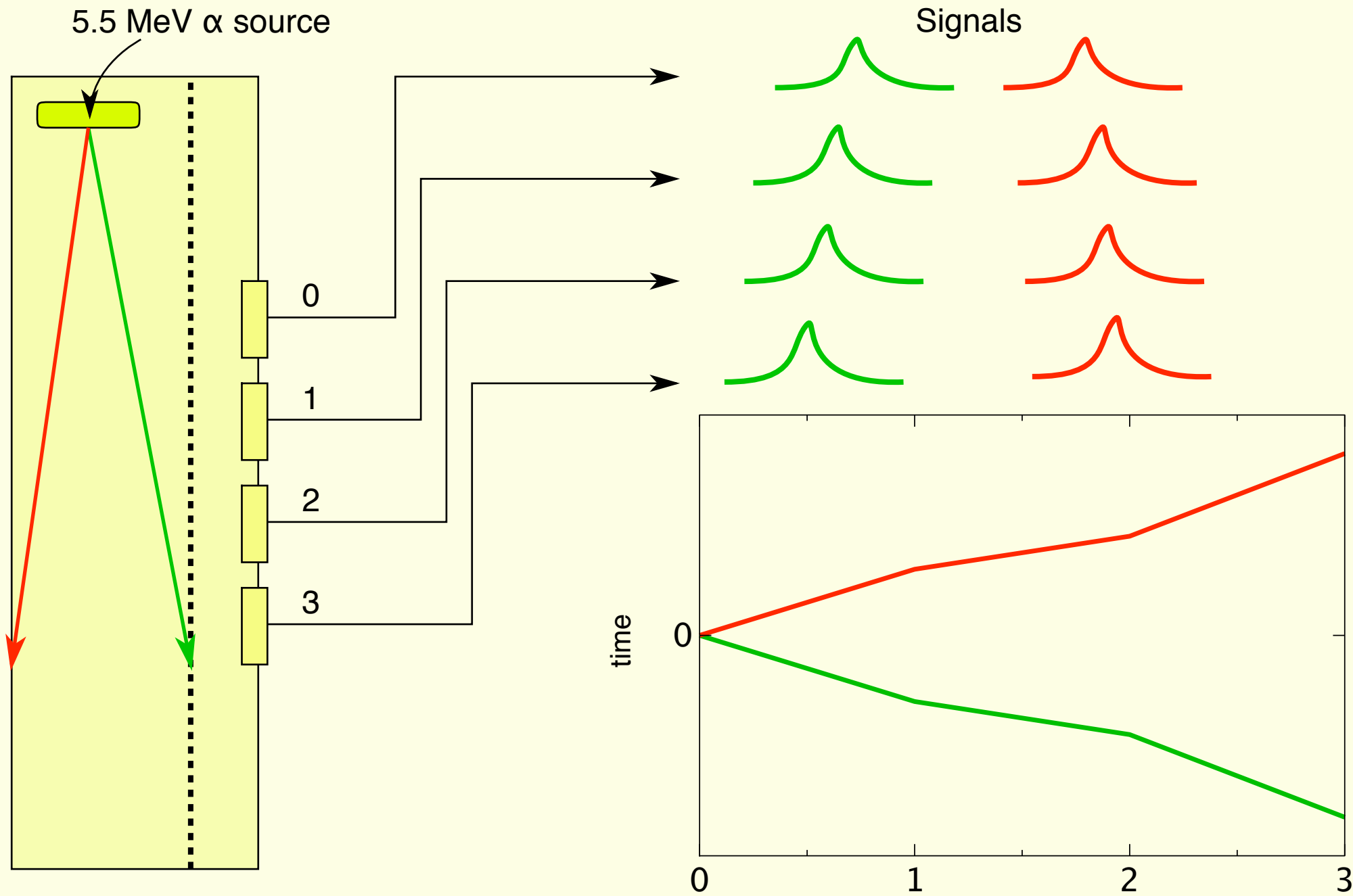

Test chamber track reconstruction

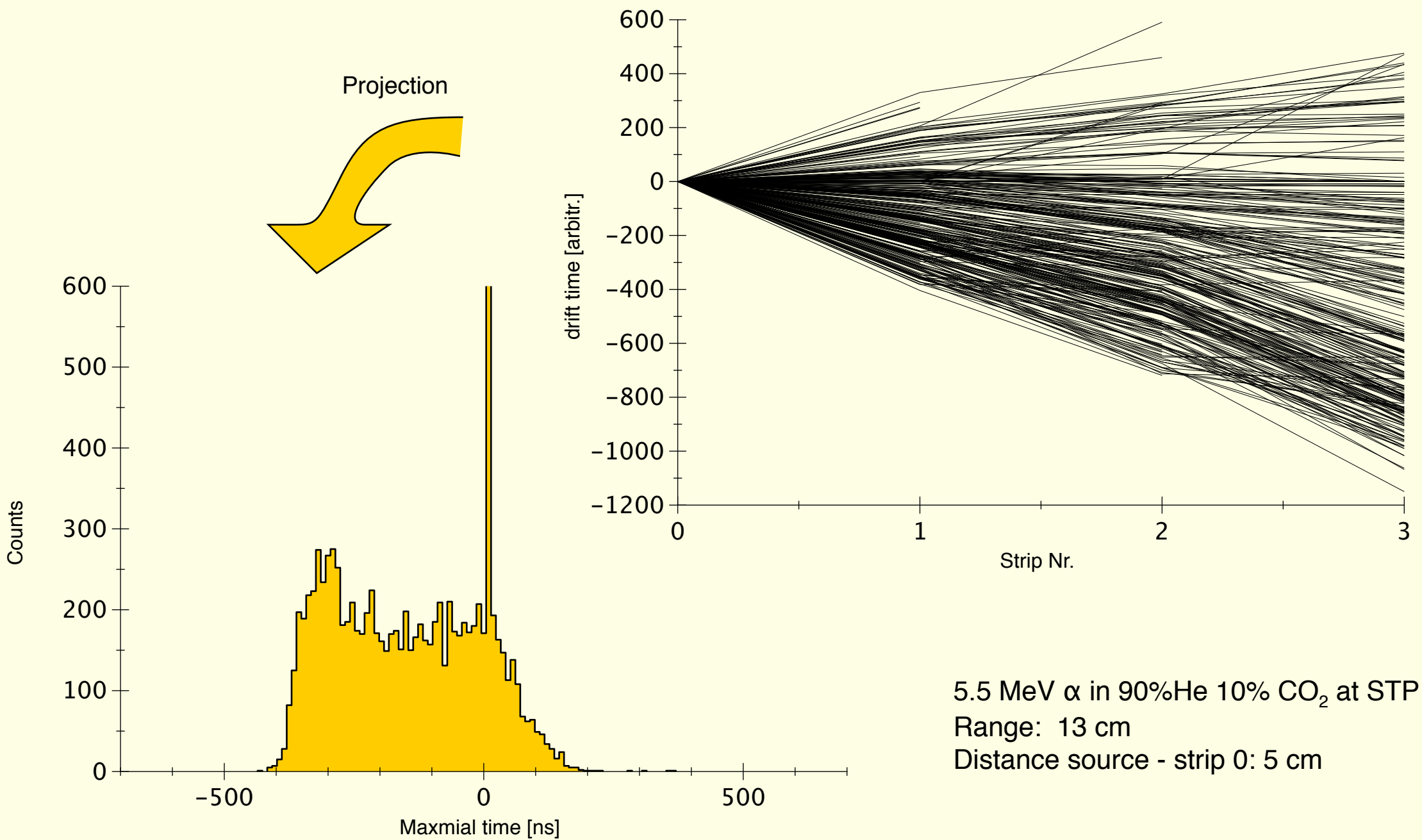

Alpha tracks: Measured and simulated

Mock chamber
measured
100 events

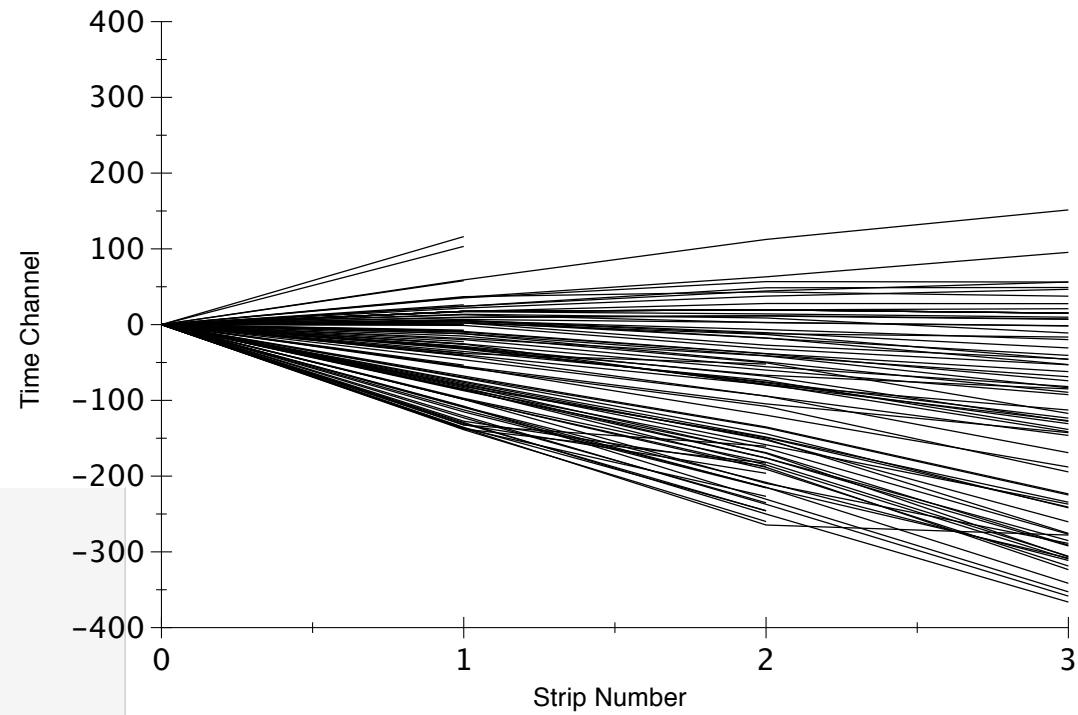

Mock chamber,
GEANT4 simulation
100 events

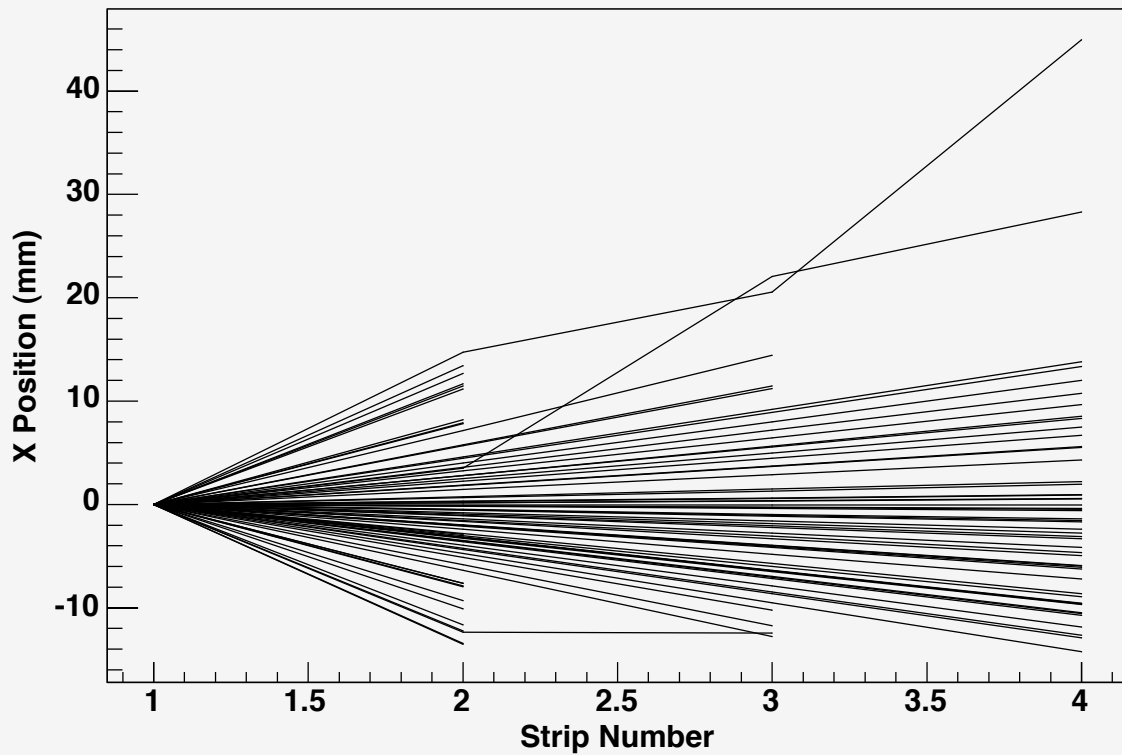

Range of ^{11}B from $\alpha(^8\text{Li}, ^{11}\text{B})\text{n}$ in 90% He 10% CO_2 gas mixture at STP

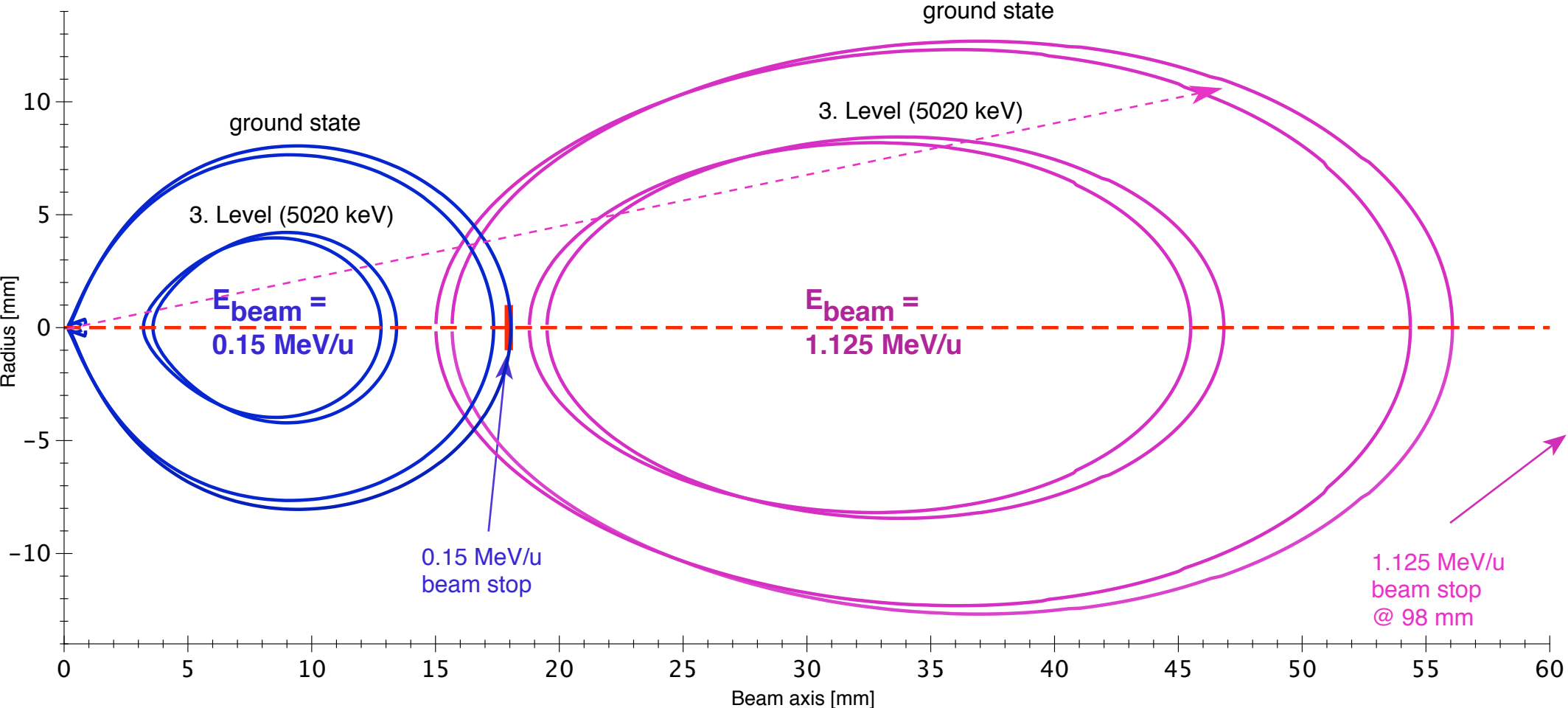

Range of ^{11}B from $\alpha(^8\text{Li}, ^{11}\text{B})\text{n}$ in 90% He
10% CO_2 gas mixture at STP

Find the optimal geometry

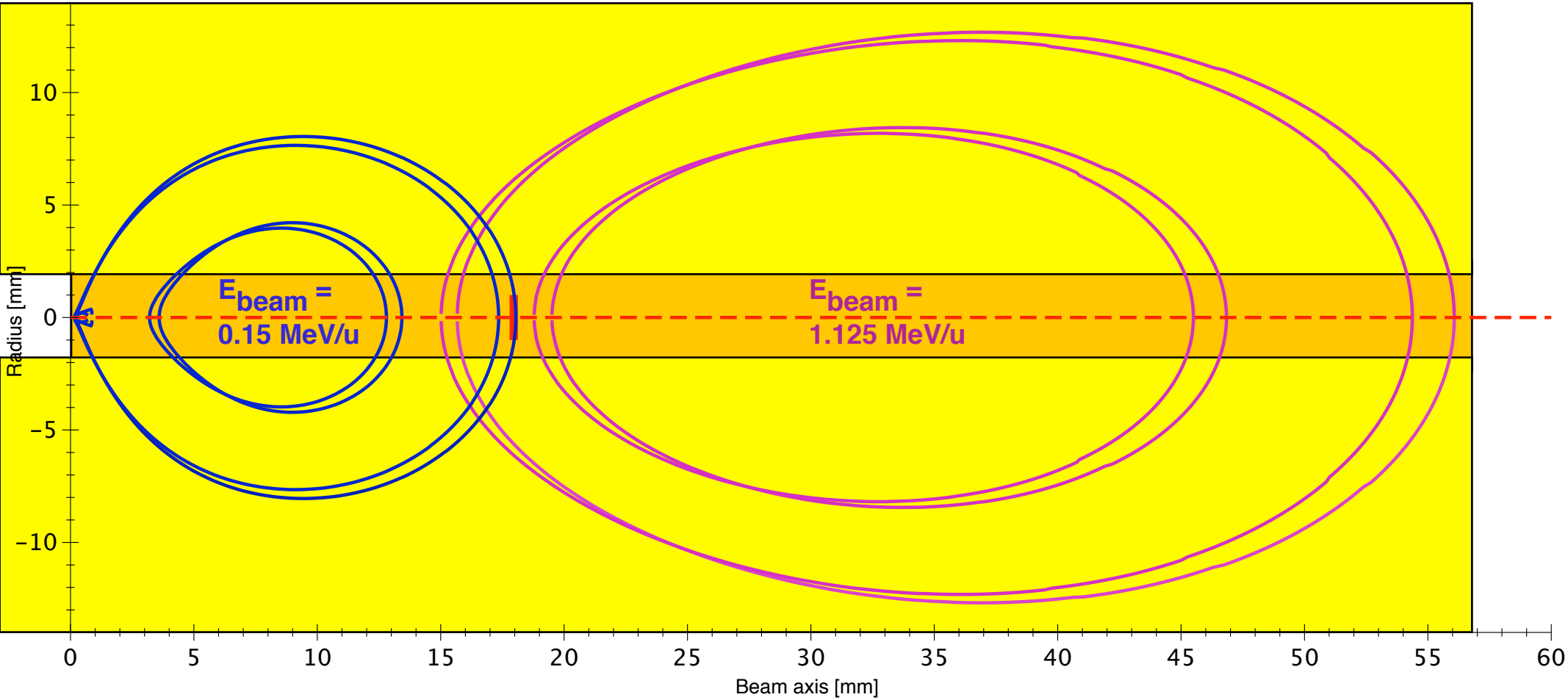

TACTIC Project Network Diagram

V.1 November 3, 2004

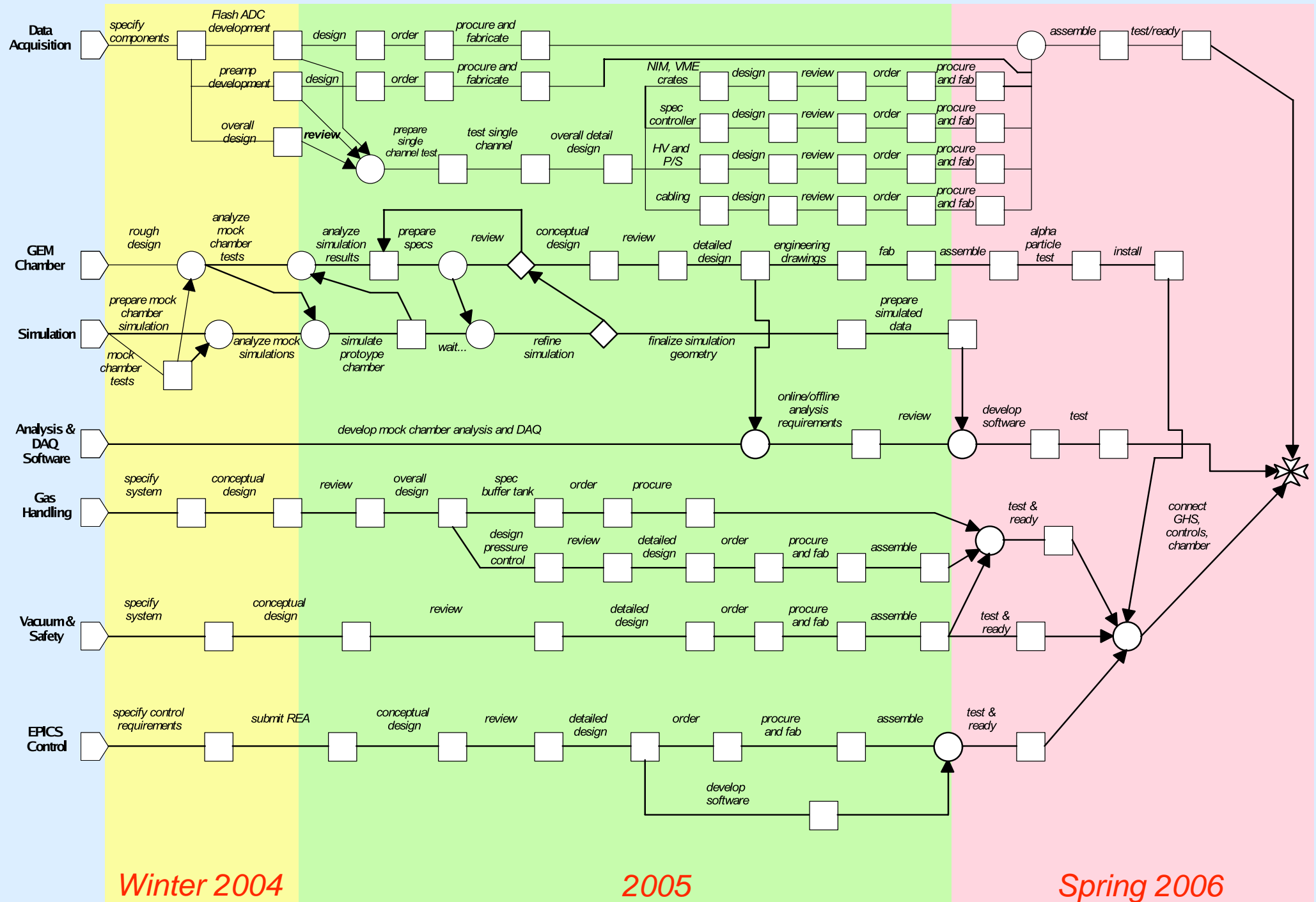

The Budget

Data acquisition comprising VME crate, 5 48-channel FlashADC cards, amplifiers, workstation, HV supply and more	60,000 CAD
Vacuum system (Turbo, backing, gauges, valves, etc...)	30,000 CAD
Chamber construction	25,000 CAD
Gas handling system / safety	25,000 CAD
EPICS control including small VME crate and PLC	20,000 CAD
<hr/>	
Total w/o tax	160,000 CAD

Next steps

- Reduced pressure: How low can we go?
- DAQ: Display tracks online using MIDAS
- Extend to more channels
- Test FlashADCs
- Test thin entrance foils
- Design prototype (already in progress)

TACTIC

tactic.triumf.ca

Pierre-André Amaudruz TRIUMF
Alison Laird U. of York
Patrick Walden TRIUMF
Lothar Buchmann TRIUMF
Dario Gigliotti TRIUMF
Götz Ruprecht TRIUMF

Marcello Pavan TRIUMF
Brian Fulton U. of York
Simon Fox U. of York
Robert Openshaw TRIUMF
Jonathan Pearson TRIUMF